

TECSYSTEM S.r.l.®

INSTRUCTION MANUAL

T2612-B

TECSYSTEM S.r.l.
Via Cristoforo Colombo, 5/C
20094 Corsico (MI)
tel. +39 - 02 - 48601011 / 4581861
Fax: +39 - 02 - 48600783

<http://www.tecsystem.it>

R.2 - 25/10/02

T2612 B protection relays

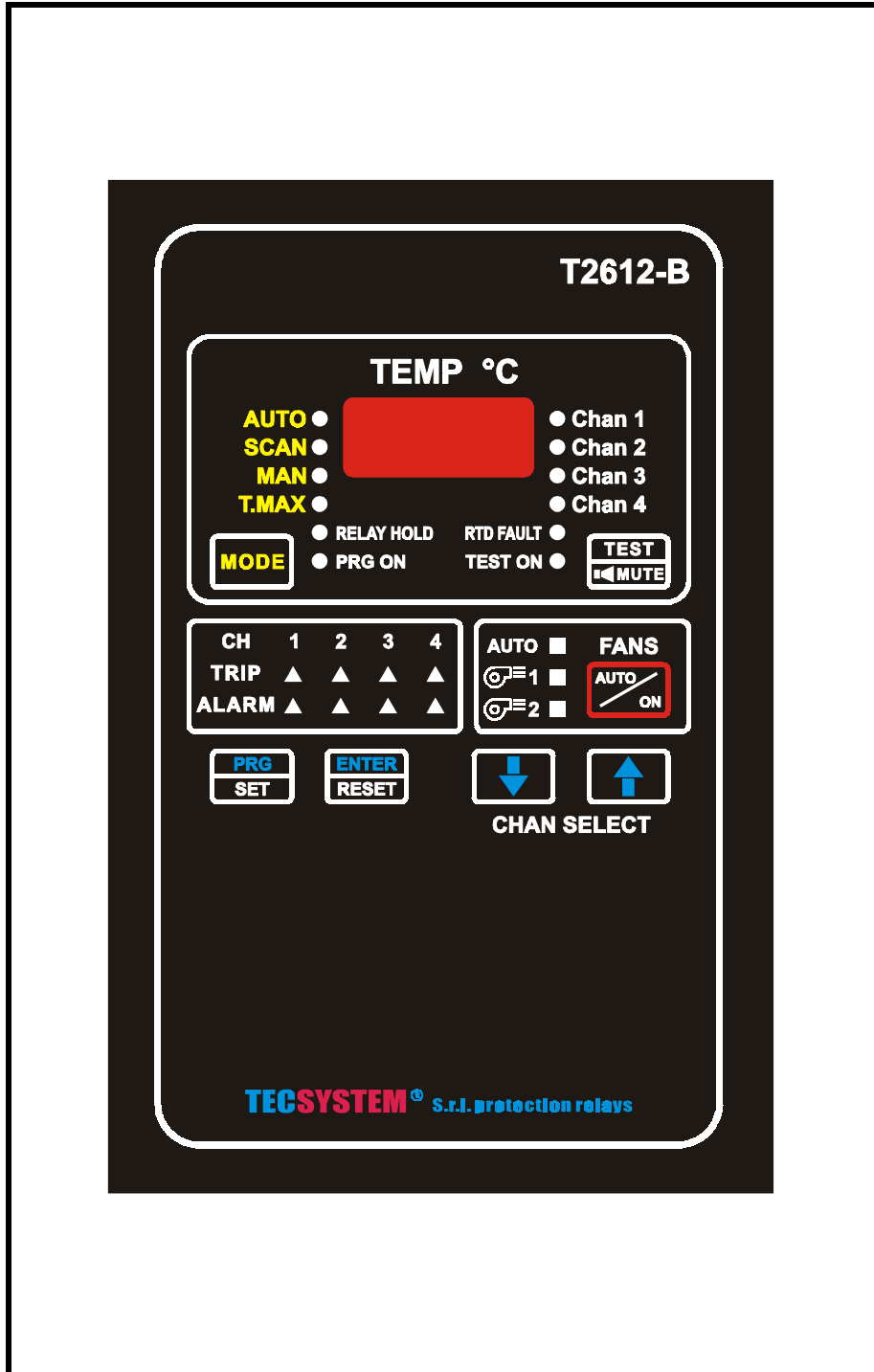

1. TECHNICAL SPECIFICATIONS

<p>POWER SUPPLY</p> <ul style="list-style-type: none"> • Rated voltage 120 or 240 Vac 50/60 Hz • Selection through voltage jumper • Tolerance +/- 10% • Power input protected by 500 mA fast fuse 	
<p>INPUTS</p> <ul style="list-style-type: none"> • 4 inputs RTD Pt100 sensors - 3 wires • 4th additional input (selectable) • Removable rear terminals • Input channels protected against electrical and magnetic noises and spikes • Sensors length cables compensation up to 500 m (1mm²) 	<p>OUTPUTS</p> <ul style="list-style-type: none"> • 2 alarm relays (ALARM-TRIP) • Output contacts capacity of ALARM, TRIP, FAULT relays: 5A 220Vac cosφ=1 • Fan 1 and Fan 2 outputs protected by separate 10A slow fuses (max 16A) • Output contacts capacity of FAN relays: 20A 220Vac cosφ=1
<p>TEST AND PERFORMANCES</p> <ul style="list-style-type: none"> • Assembling in accordance with CE rules • Protection against electrical and magnetic noises CEI-EN61000-4-4 • Dielectric strength: 2500 Vac for 1 minute from relays to sensors, relays to power supply, power supply to sensors • Accuracy: ± 1% full scale, ± 1 digit • Ambient operating temperature: -20°C to 60°C • Humidity: 90% non-condensing • Housing: painted steel panel, frontal part in polycarbonate IP65 • Burden 6VA • Data storage 10 years minimum • Digital linearity of sensors signal • Self-diagnostic circuit • Program and reading resolution: 1 digit • Opt. Protection treatment of electronic part 	<p>DISPLAYING AND DATA MANAGEMENT</p> <ul style="list-style-type: none"> • 1 display 20.5 mm high with 3 digits for displaying temperatures • LED for displaying reference channel • LED's indicating alarm or trip channel • LED indicating FAULT • Temperature monitoring from 0°C to 240 °C • 2 alarm thresholds • 2 alarm ON-OFF thresholds for fan control • Manually operated fans • Sensors diagnostic (Fcc-Foc-Fcd) • Entering the programming by frontal push button • Automatic stop of programming cycle after 1 minute of no operation • Wrong programming automatic display • Possibility of setting automatic channel scanning, hottest channel, manual scanning • Maximum temperatures and alarms storage • Frontal alarm reset key • Possibility of setting HOLD function for output relays
<p>DIMENSIONS</p> <ul style="list-style-type: none"> • 320mm x 210mm x 1.2mm • Depth 90mm 	

2) MOUNTING

Make a hole with the dimensions of 155 x 280 mm.

3) POWER SUPPLY

Select the power voltage (120 or 240 VAC) through the "Voltage change" jumper.

4) ALARMS AND FAN CONTROL ELECTRICAL CONNECTIONS

Take the removable terminal board off the unit before wiring.

ALARM and TRIP relays energize only when the prefixed temperature limits are reached.

The FAULT relay always energizes when the apparatus is powered and it resets when the Pt100's are damaged or when there is no power voltage.

The FAN relays can be used for fan control or else they can be included in the conditioning circuit of the transformer box.

In order to protect the electronic apparatus, we recommend the application of the electronic discharges of the series PT-73 - mono or double phase - which have been studied by Tecsystem Srl for this specific purpose.

5) THERMOMETRIC SENSORS CONNECTION

Each Pt100 sensor has three conductors : one white and two red (CEI 75.8)

Fig.1 shows the disposition in the terminal board of the connection cables to the unit.

Channel 2 must be always referred to the central column of the transformer.

Channel 4 must be always referred to the ambient Pt100 sensor, if you want to monitor the temperature of the transformer box through the T-2612B unit.

6) MEASURE SIGNALS TRANSPORT

All the transport cables of the Pt100 measure signals must absolutely:

- be divided from the power ones
- be realized with shielded cable with twisted conductors
- have a section of min 0.5 mm²
- be twisted if you have no shield
- be firmly fixed in the terminal board
- have tinned or silvered conductors

All the "T" series units have the sensors linearization with a max error of 1% v.f.s..

*TECSYSTEM srl has realised a special cable for the measure signal transport with all the protection requirements according to CEI Norms: **mod. CT-ES***

7) THERMOMETRIC SENSORS DIAGNOSTIC

In the event one of the thermometric sensors installed on the machine to protect is damaged, the **FAULT** relay energizes immediately, the **ALARM** and **TRIP** LED's of the damaged channel lighten and the **FAULT LED** is lightening.

The screen will automatically display a message showing the fault condition:

- **Fcc** sensor is short circuited
- **Foc** sensor is open

8) FCD FUNCTION (damaged sensor)

During the unit normal operation, if the **Fcd/YES** function has been selected, the display will show **Fcd** indicating that a sensor is damaged and the LED corresponding to the affected channel will lighten.

The **FAULT** relay will energize giving a signal to the operator.

After the replacement of the damaged sensor, you can **RESET** the alarm pushing **RESET** until the display shows the message **RST**.

9) TEMPERATURES DIAGNOSTIC

When one of the thermometric sensors surveys a temperature exceeding by 1°C the alarm limit, after 4 seconds the **ALARM** relay will energize and the **ALARM** LED of the affected channel will switch on.

The same occurs when the **TRIP** temperature limit is detected: the **TRIP** relay energizes and the **TRIP** LED corresponding to the affected channel is lightening.

When the surveyed temperature declines of 1°C below the prefixed limit for the **ALARM** and **TRIP** switching, the relays de-energize and the respective LED's switch off.

10) COOLING-FAN CONTROL

The T2612B unit, if suitably programmed, can control the ON/OFF of the transformer fans according to the set temperature values.

The fans of the machine can be controlled in two different ways:

- using the temperatures surveyed by the sensors on the three columns
CHF 1 2 3 - CH4 excluded
ALARM and TRIP LED CH1.2.3 illuminated (e.g. F1: ON at 80°C - OFF at 70°C)
(e.g. F2: ON at 90°C - OFF at 79°C)
- by an additional sensor (**CH4/YES**) for the ambient temperature inside the transformer box.
CHF 4
ALARM e TRIP LED Ch4 illuminated (e.g. F1: ON at 40°C - OFF at 30°C)
(e.g. F2: ON at 45°C - OFF at 35°C)

Press UP and DOWN key to select this function.

It is possible to operate the fans manually by pushing the MAN key.

11) FAN TEST

By programming (**hxx**) you can establish to have the fans set for 5 minutes every "xx" hours, independently on the columns or ambient temperature values.

This function has the purpose to verify periodically the fans working, when they are not in use.

By setting **h00** this functions is disabled.

12) HOLD FUNCTION

To select the hold function choose the program option **HLD-YES**. With hold function enabled, when temperature exceeds the alarm set point value, the alarm relays will energize and the alarm LED's will illuminate until you reset the relay contacts in manual reset mode. Reset is only possible when temperature falls below the set point value. To exclude the hold function select the program option **HLD-no**.

13) DISPLAY MODE

By pressing DISPLAY MODE you can select one of the three display modes:

- **HOT**: the display shows automatically the temperature of the hottest channel
- **MAN**: each channel may be viewed manually by pressing the UP or DOWN key.
- **T.MAX**: the unit shows the max. temperature recorded by the sensors and any alarm recorded after the last reset. To check the channels press UP or DOWN key.
- **SCAN**: channels are cicely every 2 seconds

14) WORKING PROGRAM CONTROL

To review the entered values momentarily press PRG key and continue to do so advancing to each programmed value. Press ENT to return to normal operating mode.

TECSYSTEM S.r.l ®

15) LAMP TEST

It is advisable to carry out this test on a regular basis to ensure all lamps are functioning normally. Pressing the TEST key at any time allows the user to test all lamps.

If any lamp is not functioning the unit must be returned for repair.

16) ALARM RELAYS TEST

All relays may be tested using the following procedure.
Press and hold the TEST key for 5 seconds. Initially all LED's illuminate, changing to the main screen display flashing **tSt**.

Release the test key when the yellow relay test LED illuminates.

The screen display will show the relay selected for testing and the respective LED will be illuminated.

The relays to test will be indicated on the display by:

- “**Fan 1**” : 1st cooling relay
- “**Fan 2**” : 2nd cooling relay
- “**Fit**” : Pt100 fault relay
- “**Alr**” : alarm relay
- “**trP**” : trip relay

Use the Scroll UP or DOWN keys to make the selection. Press the SET key to perform the test on the selected relay. To reset press the RESET key.

To discontinue operation and revert to normal operation, press the TEST key.

At the start of the test, a timer is automatically initiated which reverts the unit to normal operation if no inputs are detected for a period of five minutes.

17) ALARM RELAY EXCLUSION

The alarm relay will change contact state when the alarm set point temperature value is reached. An illuminated alarm LED provides indication of the affected channel. To reset the relay contact, press the RESET key. The alarm LED corresponding to the affected channel will start flashing to indicate that an alarm temperature value has been reached. If the set point alarm value is exceeded up to a value of 5 °C below the set trip threshold, the alarm relay will change contact state again and the alarm LED will illuminate. Once again press the RESET key to reset the relay contact. When the trip set point temperature value is reached, the trip relay will change contact state and both the yellow alarm and the red trip LED's illuminate.

18) BUZZER











T-2612B unit includes a buzzer that is operating when any alarm status occurs, except for Fan 1 and Fan 2 outputs

By pushing the TEST/MUTE key you can stop the buzzer.

In the event of a new alarm status the buzzer will operate again.

19) IMPORTANT NOTICE

Before conducting the insulation test, disconnect the power supply to the unit to avoid damage.

20) PROGRAMMING			
N°	KEYS	EFFECT	NOTES
1	PRG/SET	To begin programming press and hold PRG/SET. PRG will flash for 7 sec. When PRG stops flashing, default alarm setpoint will appear on display.	Program LED will light
2		Enter the desired Alarm setpoint	
3	PRG/SET	TRIP set T° appears	
4		Enter the desired Trip setpoint	
5	PRG/SET	"FAN" appears on display	
6		Enter FAN YES or NO	YES : FAN contacts enabled NO : FAN contacts disabled
7	PRG/SET	OFF appears on display	
8	PRG/SET	the OFF T° appears	
9		Enter desired setpoint for fan to turn off	only if YES was chosen at step 6
10	PRG/SET	ON appears on display	
11	PRG/SET	The ON T° appears	
12		Enter the desired temperature for fan to turn on	only if YES was chosen at step 6
to set up FAN2 repeat the same procedure as FAN1			
13	PRG/SET	CH4 appears on display	
14		Enter CH4 YES or NO	YES : CH4 enabled NO : CH4 disabled
15	PRG/SET	Status of FAN control will appear on the display as CHF	
16		set up CH 1,2,3 or CH4	respective LED will light
17	PRG/SET	Status of FAN control TEST will appear on the display as h00	
18		set up the number of hours	only if at the step 6 you chose YES h00 = function disabled
19	PRG/SET	Hld appears on display	
20		Enter HLd YES or NO	HLd YES = HOLD feature enabled
21	PRG/SET	Fcd appears on display	
22		Enter Fcd YES or NO	Fcd YES= control of damaged Pt100 connected
27	PRG/SET	PRG appears on display	
28		set up Prg YES or NO	Prg NO= program cannot be changed
29	ENT PRG/SET	Programming is completed. Press ENT to return to normal operating mode	The unit will perform the light test

21) PROGRAMMING REHABILITATION IN CASE OF BLOCK (Prg no)

In the event program access is blocked the display will show SET and then display "noP". To gain access, press the ENT key and return to normal operation. Touch the PRG key and then, press and hold the TEST key for approximately 7 seconds until the flashing PRG screen display ends.

NOTE: this procedure removes the lockout feature. To block access again, this feature must be reprogrammed.

22) WARRANTY

The "T" series units are warranted for a period of 12 months from the delivery date marked on the unit.

Warranty is limited to repair or replacement of the defective products and no contingent liabilities will be accepted.

Warranty will be voided if the unit is found to be tampered with or when it has been damaged as a result of incorrect input or power supply connections. Warranty will be voided if the unit is damaged as a result of transitory overvoltages. Freight expense is not covered under warranty.

In case of dispute, the qualified FORUM is the one in Milan.

23) PT100 EXTENSION CABLE: TECHNICAL SPECIFICATIONS

Cable 20xAWG 20/19 cu/stg

Section 0.55 mm²

Antiflame Insulation PVC105

In accordance with CEI 20.35 IEC 332.1

Max. working temperature: 105°C

Conformation : 4 terns of the numbered conductors (1-1-1.....4-4-4)

RRW twisted and coloured conductors

Shield cu/stg

PVC Antiflame protecting covering

External diameter 9.0 mm

Skins of 100 m

TROUBLESHOOTING

PROBLEMS	CAUSES / SOLUTIONS
The unit will not switch on, with control power energized	Check the terminal block for correct installation. Check for voltage at the terminal block.
Channel 4 is indicating fault and displaying FOC (only three Pt100 sensors are connected)	Wrong programming of the unit. <i>Repeat programming.</i>
One of the 4 channels is indicating fault and displaying FOC/FCC	Check the sensors connection. Look for damaged sensors. <i>Replace damaged sensor</i>
When switching the unit on-off, the alarm and trip relays energize	Strong electrical noise is being picked up on the power line. <i>Install a transient suppressor (PT-73.)</i> Check to ensure the shield of the sensor cable is connected to the panel ground. <i>Install shielded cable (Mod. CT-ES) or twist the sensor conductors.</i>
All the sensors are displaying FCC.	Wrong wiring connections. The terminal block is upside-down.
The temperature indicated by one or more channels is wrong.	The sensors are defective. <i>Check the sensor resistance with an Ohmmetre.</i> The unit is calibrated incorrectly. Return for repair.
Sudden activation of the trip relay with normal operating temperature. One channel caused the occurrence.	Sensor defective (Fcd). <i>Replace the sensor.</i>

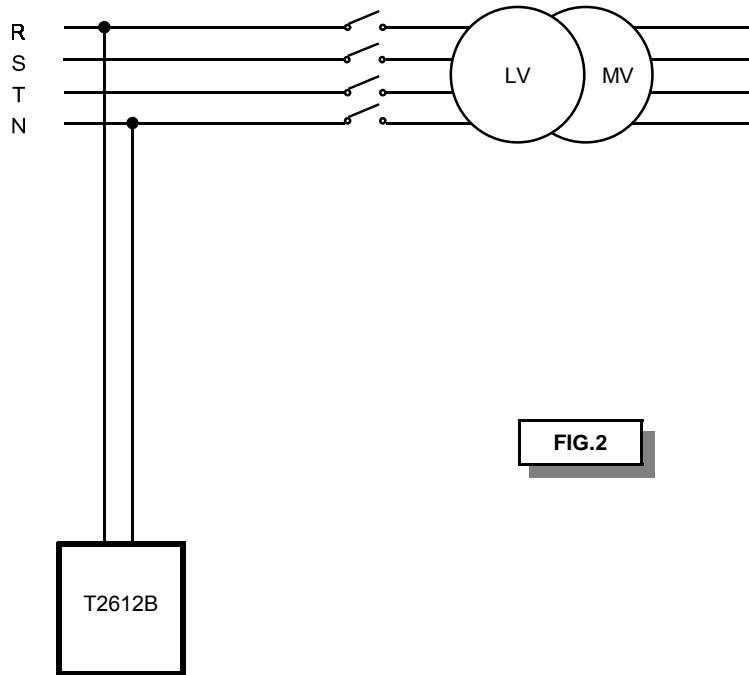

FIG.2

Possible configuration of Alarm and Fault relays parallel connection.

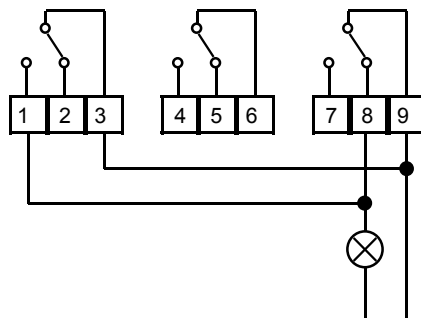
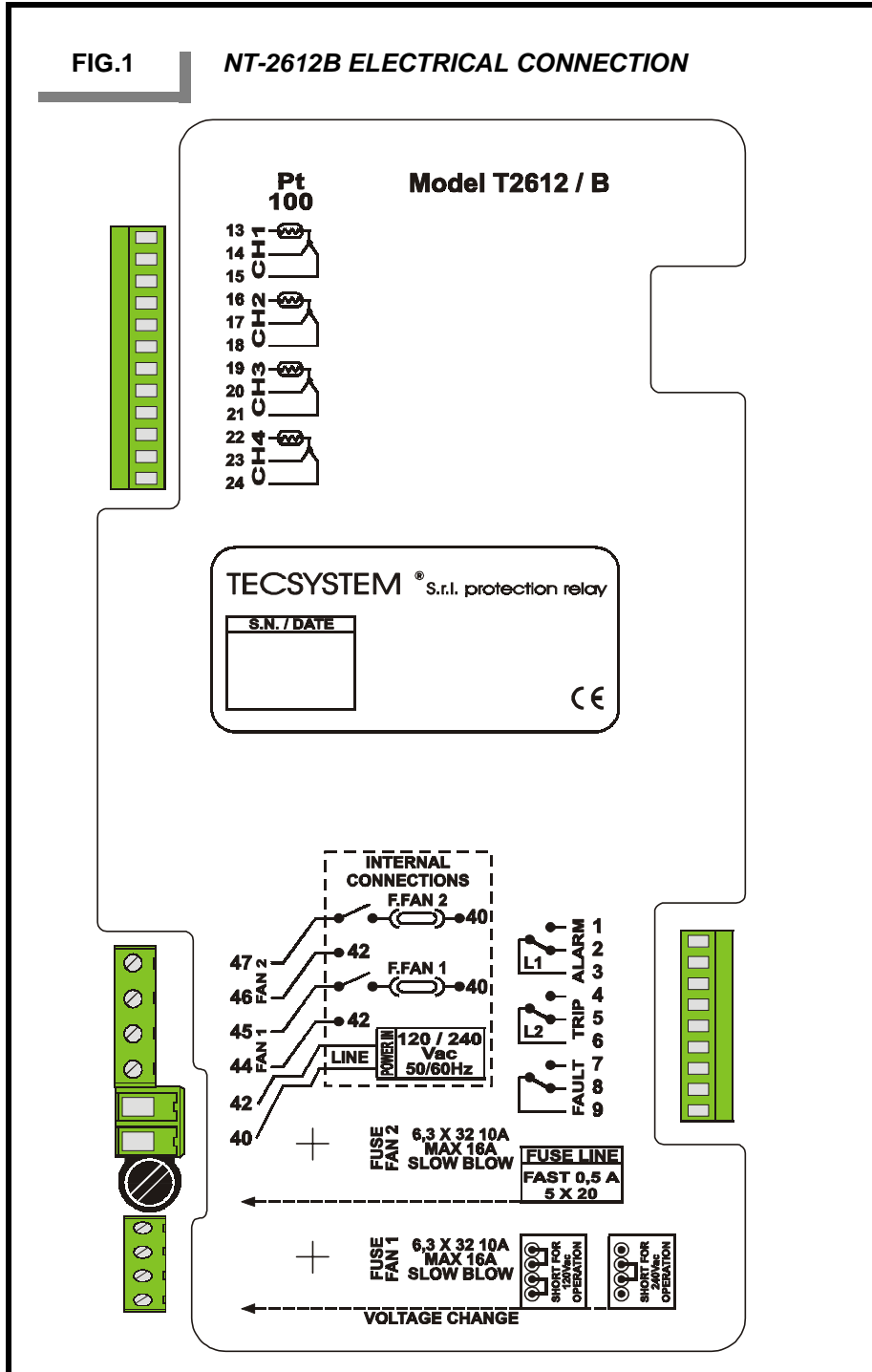
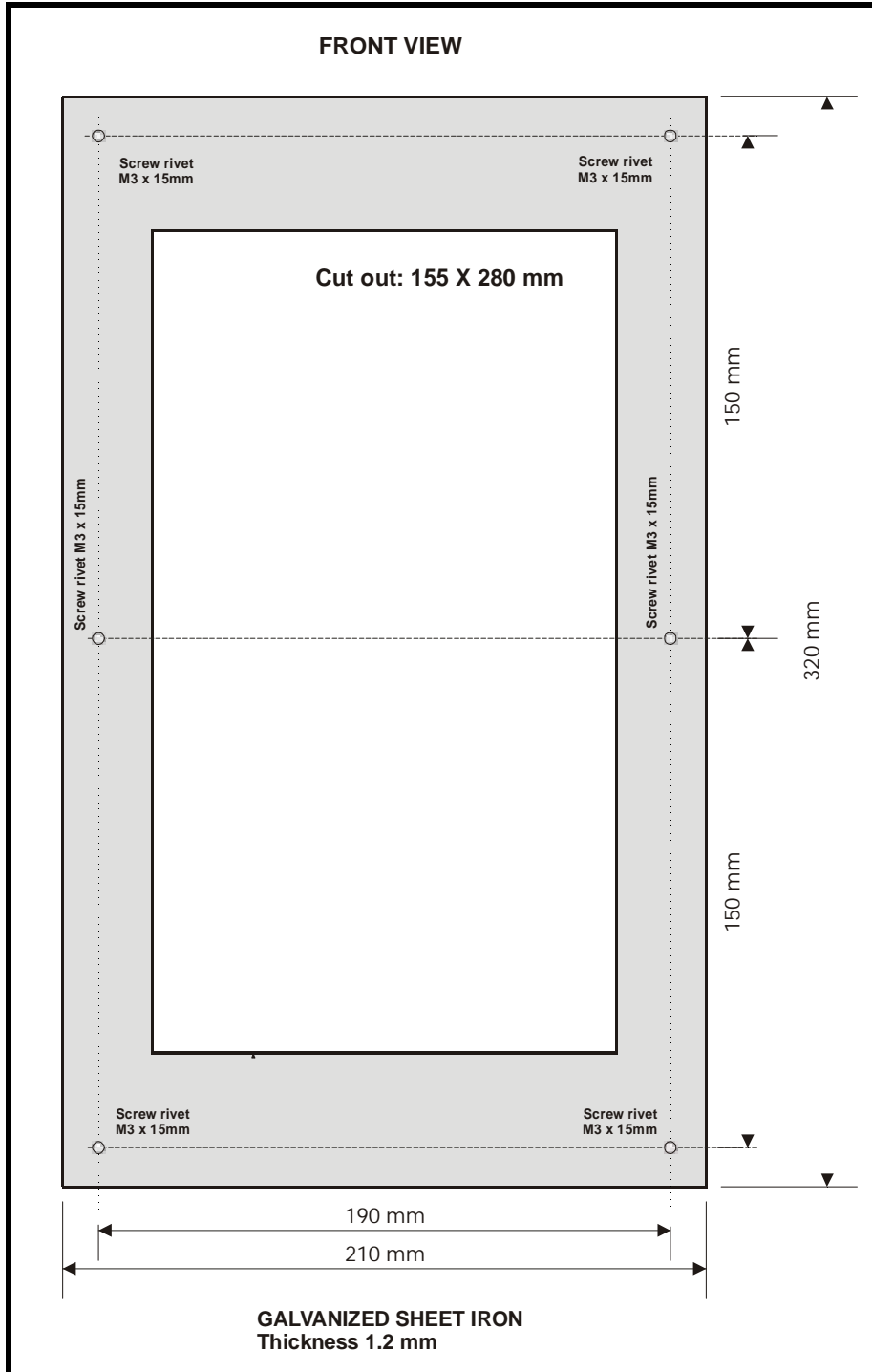

Fig.3

FIG.1 NT-2612B ELECTRICAL CONNECTION





TECSYSTEM S.r.l.®

NOTE:

T2612 B TEST DESCRIPTION

The unit was submitted to the following tests during production:

N°	Description
1	PC board test
2	Input test
3	Test of relay contacts and outputs
4	Key test
5	Lamp test
6	Calibration at 100 and 200°C (for temperature monitoring units)
7	Software test
8	Burn-in minimum 24h

Date of shipment: